

Intended purpose



Mipa application guidelines for multi-layer coatings in red colours aim to provide assistance to painters in achieving optimal consistency in colour and effect. This is the instruction in how to apply the current colours like **Renault NNP** ("Rouge Flamme Nacre"), **Mazda 46V** ("Soul Red Crystal"), **Mazda 41V** ("Soul Red Metallic") and **Ford Ruby Red Pearl**.

Reason: Opaque metallic and effect colours, when applied appropriately, do not cause colour deviations due to different coat thicknesses, but this is a problem when applying transparent multi-layer effect colours.

The transparent 2nd layer, also called "Coating 2", is generally susceptible for coat thickness related colour and effect deviations. The "thicker" the transparent layer is applied the "darker" the colour or the effect of the undercoating, also called "Coating 1", is reduced.

Therefore, it is essential to determine by spraying samples in the run-up to the application how many spray coats of Coating 2 are necessary to exactly match the original colour of the vehicle.

The simple formula is therefore:

Coating 1 covering + ? numbers of layers of Coating 2 + clearcoat = original colour

The recommended coating structure is as follows:

Step 1: Colour matching

Colour matching is made directly on the damaged coating of vehicle by means of Mipa MCS Colorbox or the colour measure device SSP. Based on this colour determination, the corresponding Mipa WBC formulation for Coating 1 and Coating 2 are mixed according to the MipaMix formulation.

Step 2: Spray samples

Apply a uniform and covering layer of "Coating1" on several spray out cards (e.g. on spray out cards with black/white pattern or Coil Coating-cards). Generally, 4-5 spray out cards should be enough.

Important: Do not forget to note visibly on each card the number of layers applied. Write it for example on the back site.

Afterwards, overcoat each card with 1, 2, 3 or 4 uniform layers of the transparent effect paint "Coating 2".

Consequently, you will have the following samples for colour match:

1. "Coating 1" + 1 layer "Coating 2"
2. "Coating 1" + 2 layers "Coating 2"
3. "Coating 1" + 3 layers "Coating 2"
4. "Coating 1" + 4 layers "Coating 2"

At the end apply the clearcoat and let it dry.

Step 3: Compare the colour with the original coating

The range of prepared spray samples should have approximately the following colour grading:

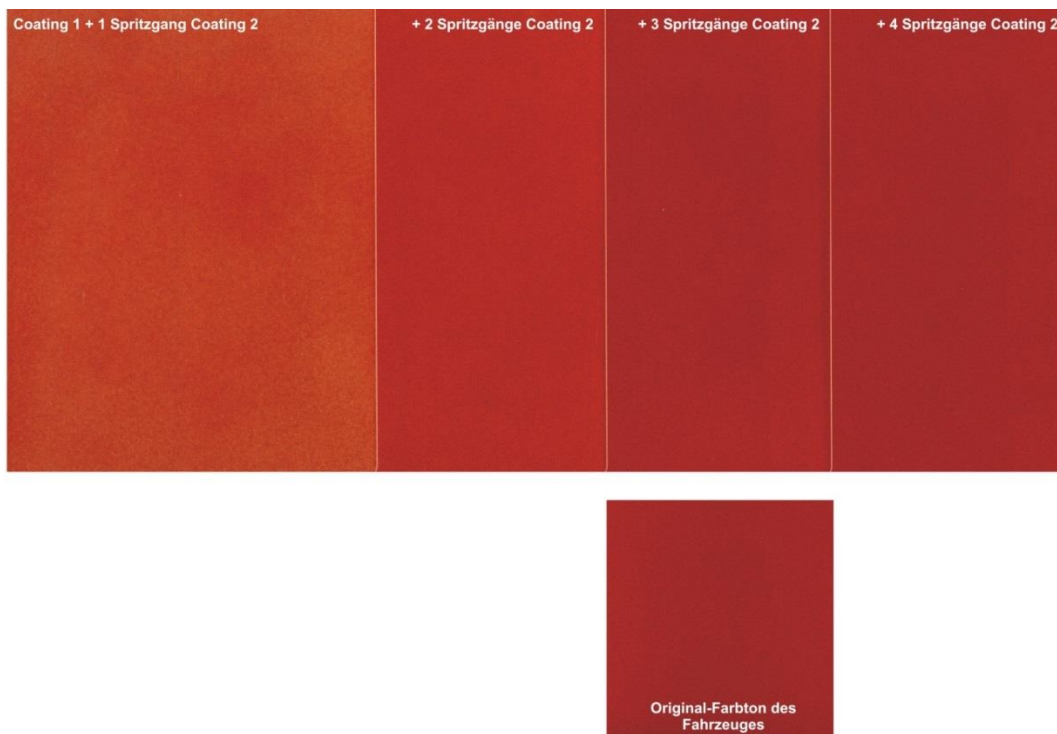

The painter can now inspect visually and identify the colour that matches the best with the original finish. In our example, it's the sample number 3 with 3 layers of "Coating 2".

Step 4: Refinish

Please note that due to the difficult colour matching only blending is possible.

Substrate preparation:

After appropriate pre-treatment, prime the area to repair or new parts with a Mipa 2K filler in a shade that is specified by MipaMix.

In case of sanding fillers, it is recommended to start dry sanding with grit P 600 and working up to finer abrasives using an orbital sander + fine wet sanding with grit P 1000. Corners and edges should be sanded only manually to avoid sand through areas.

The surfaces to be painted need to be degreased and cleaned very thoroughly as already tiniest dust particles or other superficial disturbances may cause visible imperfections in the surface.

Initial situation: door panel filled shall be painted in the same colour as the wing

Wing panel filled and sanded, ready to be painted **faultless door, sanded slightly with very fine grit, blending zone**

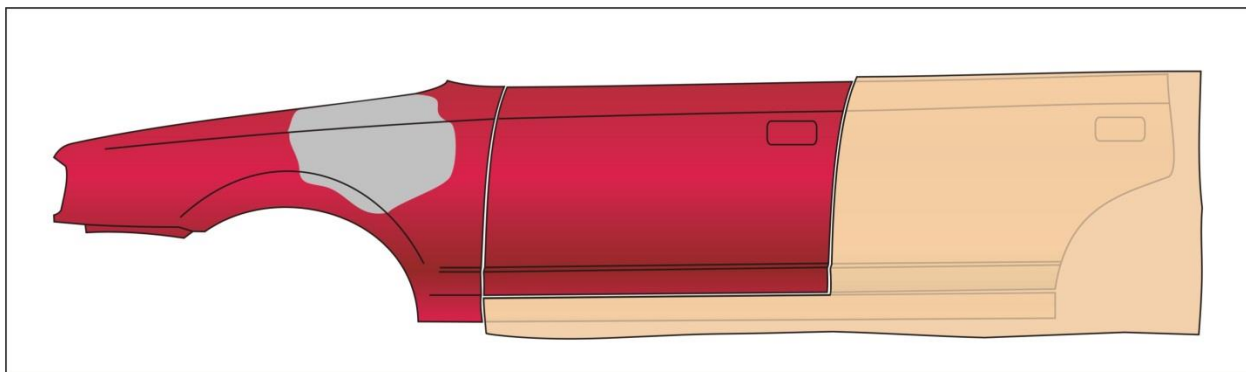

Application of Mipa WBC Beispritzlack:

First, applying 1 wet closed film of Mipa WBC Beispritzlack on the complete surface to be painted - in this case wing + door (coating area is grey highlighted). After a short intermediate flash-off time of approx. 5 minutes, Coating 1 can be applied.

Wing panel and door are pre-coated with Mipa WBC Beispritzlack

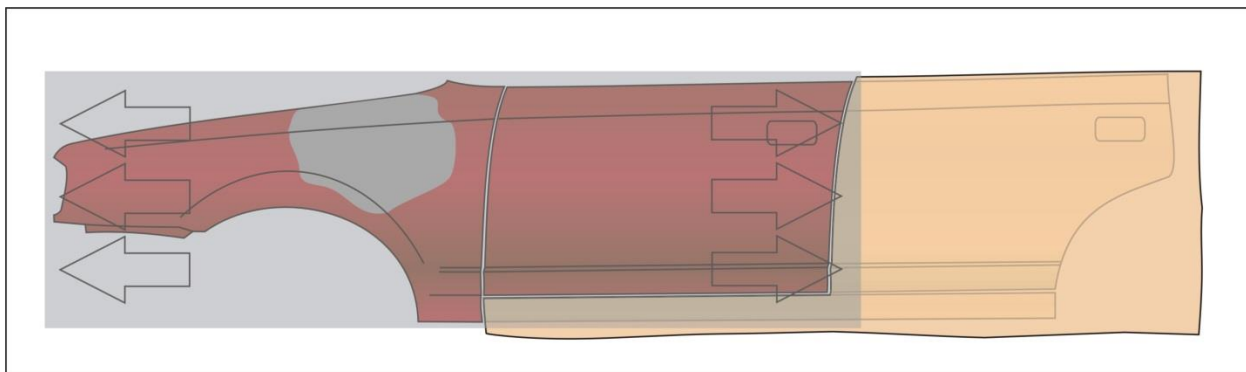

Application of Coating 1:

The surface to be refinished – in this case wing panel + front part of the door – is coated with the pre-paint “Coating 1”. This coat is applied tapering into the still intact existing finish on the front part of the door to ensure a homogeneous colour effect. It is important to take care that filled surfaces and imperfections are recoated absolutely covering.

The application is carried out according to the technical data sheet "Mipa WBC 2-Schicht-Basislack".

Important: Since it is a multilayer coating and in order to improve the through drying, Coating 1 needs to be crosslinked with the hardener Mipa WBC-Härter as follows (Mix Coating 1 immediately prior to use!):

"Coating 1" = Mipa WBC basecoat + 5 % by weight or by volume Mipa WBC hardener (stir first the hardener thoroughly in the WBC paint), then thin by adding 10 - 20 % of Mipa WBC-Verdünnung or Mipa WBS Beschleuniger.

Intermediate flash-off time: at least 20 minutes at room temperature

Application of Coating 1:

Apply Coating 1 covering the wing and fading out into the front part of the door

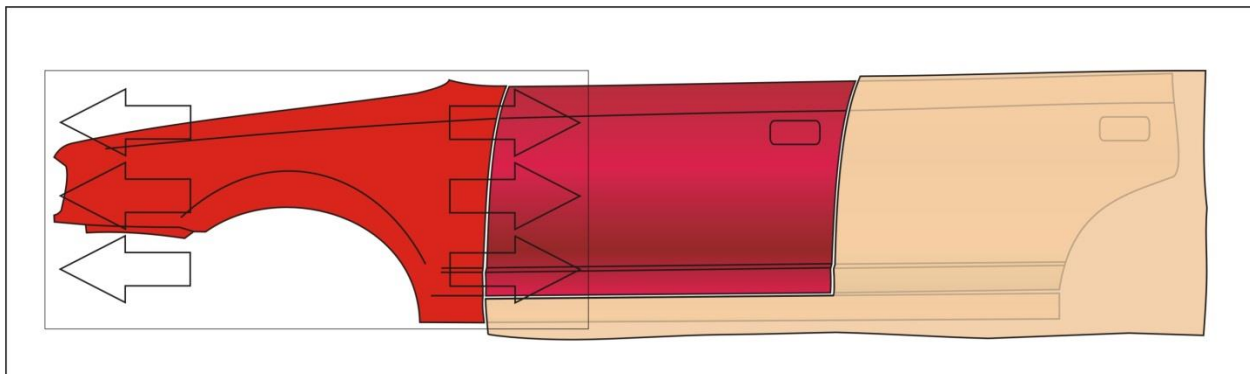

Application of Coating 2:

"Coating 2" is applied typically without hardener as follows (Mix Coating 2 immediately prior to use!):

Apply evenly 1 - 4 spray passes of the transparent colour (in this case, 3 passes have been determined beforehand) on the wing and on the middle part of the door until the best possible colour and effect transition is achieved. . In doing so, fade out also into the surface of the door to ensure an effect as seamless as possible and a smooth transition.

Important: The fading out zone of Coating 1 must be applied "overlapping"!

The spray pressure should not exceed 2.0 bar inlet pressure to avoid mottling.

Wing coated with 3 passes of Coating 2 and fadeout into the middle part of the door

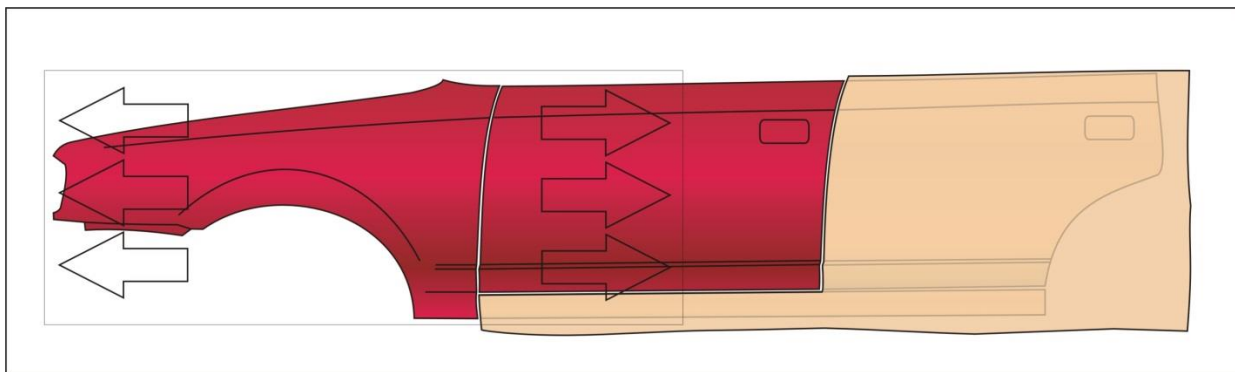

Clearcoat application:

Before applying the clearcoat, the flash-off time should be at least 20-30 minutes at room temperature or approx. 15 minutes at 40° C.

As soon as the WBC painted surface has been dried sufficiently, the clearcoat can be applied.

It is recommended to use Mipa 2K-HS clearcoats according to corresponding Mipa technical data sheets.

Clearcoat application:

Clearcoat applied on wing panel + door

